

Productinfo: OUT-Stack-Heater for Impactor

Heater for Impactor

The large heater serves the impactor with his parts.

The heater is fastened to the suction tube by means of a flange and stabilizes the internal parts.

Heater with 5 mm thick thermal mineral fibre insulation.

Heater cartridge: 400 W, 230 V, with NiCr-Ni Thermocouple to regulate exactly the temperature according to EN.

Shape: Aluminum-square tube: 120 x 120 x 285 mm.

In the delivery: 5 m power cable and cable for NiCr-Ni.

Weight: 4 kg

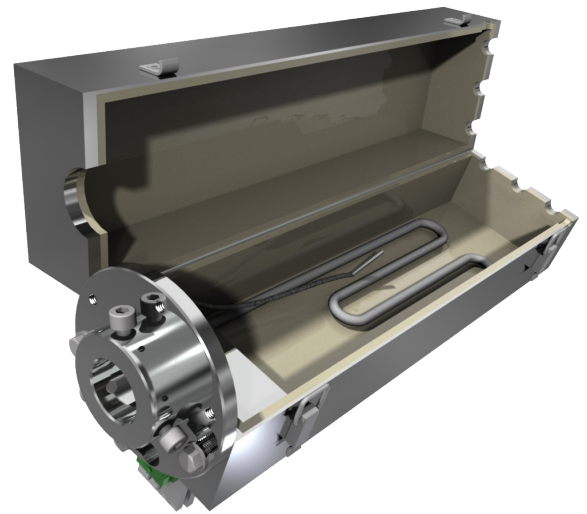

Article-No: 35.09

Heater with impactor and accessories

